

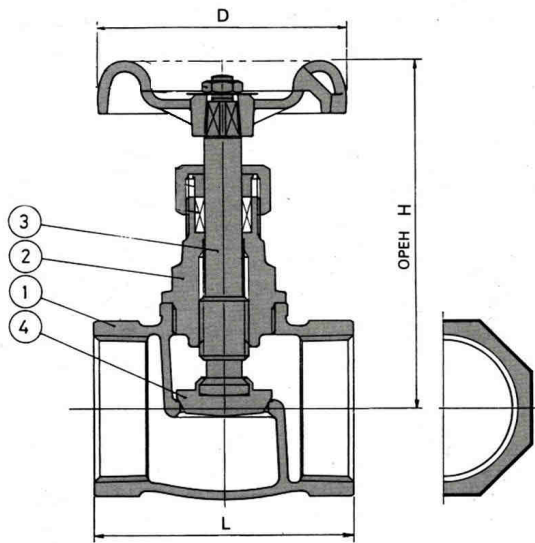

BRONZE GLOBE VALVES To BS5154

Screwed bonnet, screwed ends.



Materials

No.	Name of Parts	Materials	Material Standard
1	Body	Cast Bronze	BSEN1982 CC491K
2	Bonnet	Copper alloy	BSEN1982 CC754S
3	Stem	Copper alloy rod	BSEN12164 CW603N
4	Disc	Cast Bronze	BSEN1982 CC491K

Working Pressure

Working Pressure Non-Shock		Test Pressure	
Saturated Steam	Cold Water Oil, Gas	Shell (Water)	Seat (Water)
8.6 Bar	16 Bar	24 Bar	18 Bar

Dimensions

Mark	Size	1/2	3/4	1	1 1/4	1 1/2	2	2 1/2	3
	L	in.	1.89	2.09	2.48	2.87	3.23	2.86	4.65
	mm	48	53	63	73	82	98	118	136
H	in.	2.91	3.03	3.50	4.33	5.16	5.67	7.20	8.27
	mm	74	77	89	110	131	144	183	210
D	in.	2.17	2.17	2.48	2.76	3.15	3.54	4.33	4.92
	mm	55	55	63	70	80	90	100	125
Wt.	lb	0.53	0.71	0.99	1.61	2.34	3.55	6.58	9.42
	kg	0.24	0.32	0.45	0.73	1.06	1.61	2.99	4.28

Note:

End threads conform to British Standard pipe threads.

Toyo Valve Co., Ltd.