

D15SI

Pressure Reducing Valve

Diaphragm-actuated with stainless steel Cartridge insert

APPLICATION

Pressure reducing valves of this type protect installations against excessive pressure from the supply. They can be used for household, industrial or commercial applications within the range of their specification.

By installing a pressure reducing valve, pressurisation damage is avoided and water consumption is reduced.

The set pressure is also maintained constant, even when there is wide inlet pressure fluctuation.

Reduction of the operating pressure and maintaining it at a constant level minimizes flow noise in the installation.

APPROVALS

- WRAS (up to 23 °C)

SPECIAL FEATURES

- Patented cartridge solution for easy assembly and maintenance
- One cartridge insert fits all nominal widths, making warehousing efficient
- Meets all requirements of EN 1567
- All metal parts with contact to the flow made of stainless steel
- Functionality and performance have been confirmed by an accelerated life test with over 400,000 cycles (requirement acc. to EN 1567: 200,000 cycles)
- All materials are UBA conform



TECHNICAL DATA

Media	
Medium:	Drinking water
Optional medium:	Compressed air* ¹ acc. ISO 8573-1 class 2 in consideration of valid standards (e.g. EN 12502)
Connections/Sizes	
Connection sizes:	2 1/2" - 4"
Nominal sizes:	DN65 - DN100
Pressure values	
Max. inlet pressure:	16 bar
Outlet pressure:	1.5 - 6.5 bar
Nominal pressure:	PN 16
Min. pressure drop:	1.0 bar
Operating temperatures	
Max. operating temperature medium:	65 °C

Note: *¹ As part of an installation being approved according to PED requirements, this product must also be certified.

CONSTRUCTION

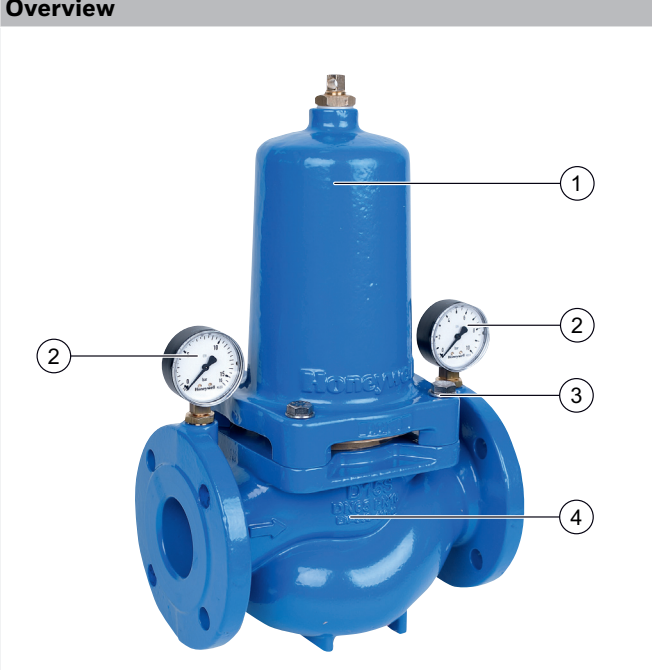
Overview	Components	Materials
	1 Spring bonnet with adjustment screw	Ductile cast iron (EN-GJS-400-15 EN 1563), coated with PA (polyamide)
	2 Pressure gauge	-
	3 Screws and nuts	Stainless steel
	4 Housing with PN16 flanges per ISO 7005-2, EN 1092-2, face to face length acc. EN 558-1	Ductile cast iron (EN-GJS-400-15 EN 1563), coated with PA (polyamide)
Not depicted components:		
	Adjustment spring	Spring steel
	Diaphragm and seals	EPDM
	Cartridge insert	Stainless steel
	Groove ring and sealing disc	EPDM

METHOD OF OPERATION

Spring loaded pressure reducing valves operate by means of a force equalising system. The force of a diaphragm operates against the force of an adjustment spring. If the outlet pressure and therefore diaphragm force fall because water is drawn, the then greater force of the spring causes the valve to open. The outlet pressure then increases until the forces between the diaphragm and the spring are equal again.

The inlet pressure has no influence in either opening or closing of the valve. Because of this, inlet pressure fluctuation does not influence the outlet pressure, thus providing inlet pressure balancing.

TRANSPORTATION AND STORAGE

Keep parts in their original packaging and unpack them shortly before use.

The following parameters apply during transportation and storage:

Parameter	Value
Environment:	clean, dry and dust free
Min. ambient temperature:	5 °C
Max. ambient temperature:	55 °C
Min. ambient relative humidity:	25 % *
Max.ambient relative humidity:	85 % *

*non condensing

INSTALLATION GUIDELINES

Setup requirements

- Install in horizontal pipework with spring bonnet directed upwards
- Install shut-off valves
- The installation location should be protected against frost and be easily accessible
 - Pressure gauge can be read off easily
 - Simplified maintenance and cleaning
- Install downstream of the filter or strainer
 - This position ensures optimum protection for the pressure reducing valve against dirt
- Provide a straight section of pipework of at least five times the nominal valve size after the pressure reducing valve (in accordance with EN 806-2)
- Requires regular maintenance in accordance with EN 806-5

Installation Example

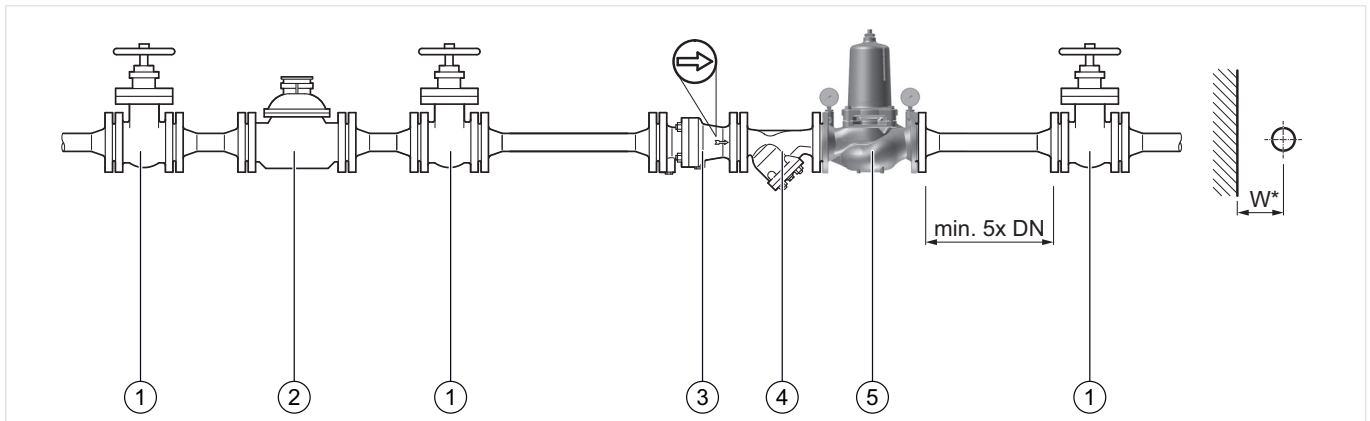

Fig. 1 Standard installation example for the pressure reducing valve

- 1 Shut-off valve
- 2 Water meter
- 3 Non return valve
- 4 Strainer
- 5 Pressure reducing valve

Connection sizes:			
DN	65	80	100
inch	2 1/2"	3"	4"
Distance in mm (W*):	120	130	145

* Required installation distances between the centerline of the pipework and the surrounding in dependency of the connection size.

TECHNICAL CHARACTERISTICS

kvs-Values

Connection sizes:			
DN	65	80	100
Inch	2 1/2"	3"	4"
k _{vs} -value (m ³ /h):	49	51	56

Pressure drop characteristics

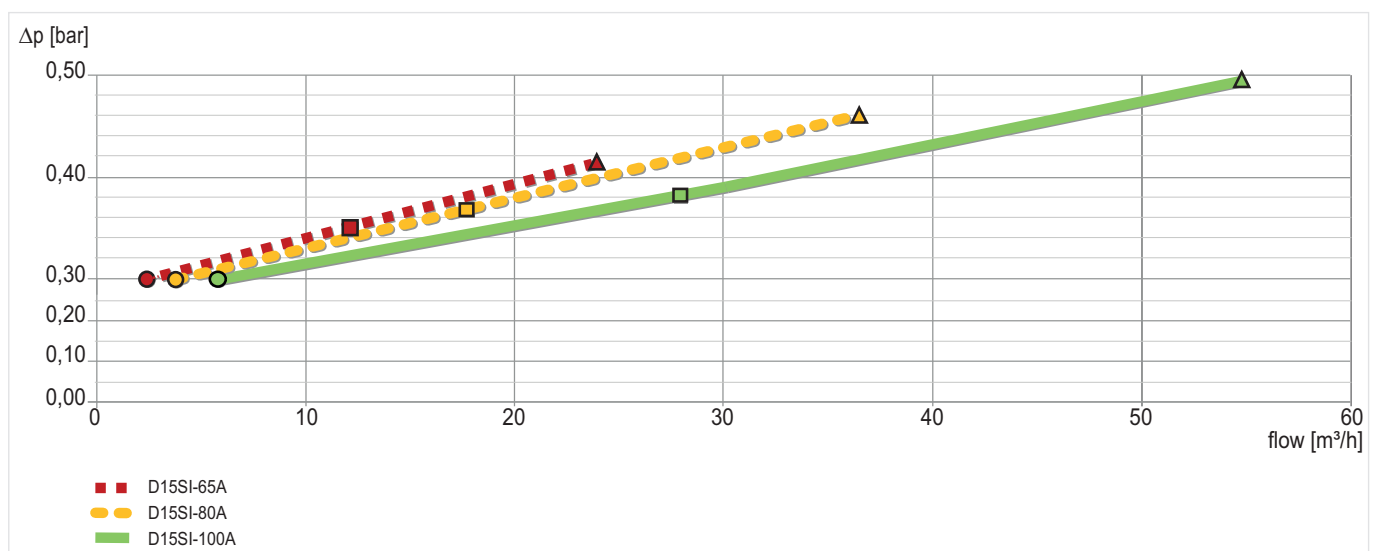
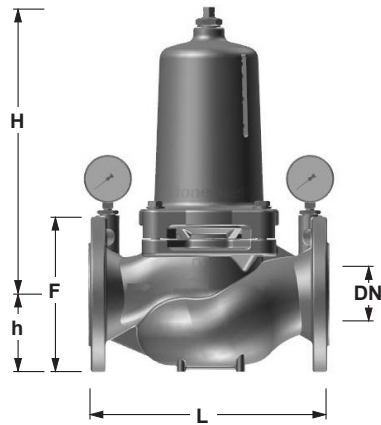

Fig. 2 Pressure drop within the valve in dependency of the flow rate and the used connection size (Sizes DN65 - DN100)

	DN65	DN80	DN100
● \triangleq 10% of standard flow	2.4 m ³ /h	3.6 m ³ /h	5.6 m ³ /h
■ \triangleq 1m/s flow rate	12 m ³ /h	18 m ³ /h	28 m ³ /h
▲ \triangleq 2m/s flow rate = QN	24 m ³ /h	36 m ³ /h	56 m ³ /h

DIMENSIONS

Overview



Parameter		Values		
Connection sizes:	Inch	2 1/2"	3"	4"
Nominal sizes:	DN	65	80	100
Weight:	kg	30.5	32	34.5
Dimensions:	L	290	310	350
	H	370	370	370
	h	93	100	110
	F	185	200	220

Note: All dimensions in mm unless stated otherwise.

ORDERING INFORMATION

The following tables contain all the information you need to make an order of an item of your choice. When ordering, please always state the type, the ordering or the part number.

Options

The valve is available in the following sizes: 2 1/2", 3" and 4".

- standard
- not available

		D15SI-...A
Flanges:	PN 16, ISO 7005-2, EN 1092-2, face to face length acc. EN 558-1	•
Housing:	Ductile cast iron (EN-GJS-400-15 EN 1563), coated with PA (polyamide)	•

Note: ... = space holder for connection size

Note: Ordering number example for 2 1/2" and type A valve: D15SI-21/2A

Spare Parts

Pressure Reducing Valve D15SI, from 2016 onwards

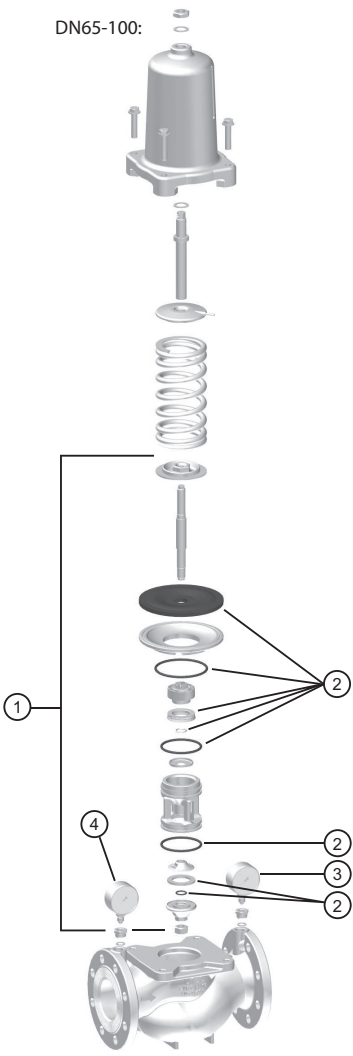
Overview	Description	Dimension	Part No.
	1 Valve insert complete	DN65 - DN100	0904122
	2 Set of seals complete	DN65 - DN100	0904121
	3 Pressure gauge	0 - 10 bar	M39M-A10
	4 Pressure gauge	0 - 16 bar	M39M-A16

Environmental & Energy Solutions

Honeywell GmbH
 Hardhofweg
 74821 MOSBACH
 GERMANY
 Phone: (49) 6261 810
 Fax: (49) 6261 81309
<http://ecc.emea.honeywell.com>

Manufactured for and on behalf of the
 Environmental and Combustion Controls
 Division of Honeywell Technologies Sàrl, Z.A.
 La Pièce 16, 1180 Rolle, Switzerland
 by its Authorised Representative Honeywell GmbH
 ENOH-1059GE23 R0217
 Subject to change
 © 2016 Honeywell GmbH

