

RED-WHITE

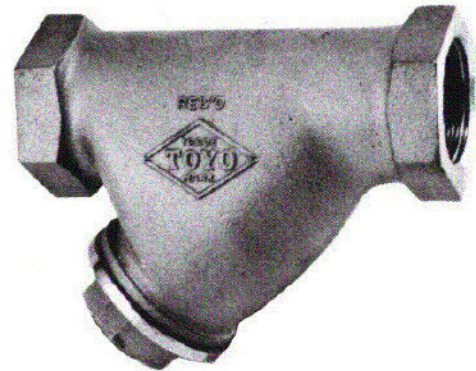

150-POUND BRONZE STRAINERS

Screwed cap, Y-pattern, screwed ends.

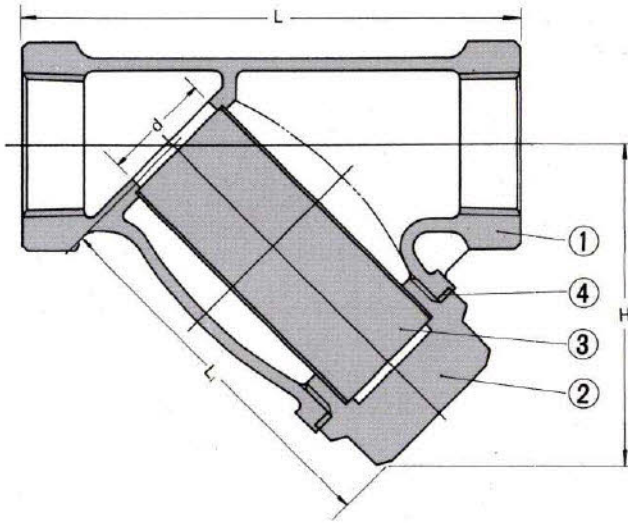

Materials

No.	Name of Parts	Materials	Material Standard
1	Body	Bronze	BSEN 1982 CC491K
2	Cap	Copper Alloy	BSEN 12165 CW617N
3	Screen	Stainless Steel	BSEN 10088-2 1.4301 ^(a,b)
4	Gasket	Non-asbestos	

- a. 1.4301 equivalent to 304 stainless steel.
- b. 1.4401 (316) stainless steel is optional

Working Pressure

Working Pressure	Test Pressure
Non-Shock	
Water, Oil	Body (Water)
20 Bar	30 Bar

Note:
End threads conform to the American or British Standard pipe threads.

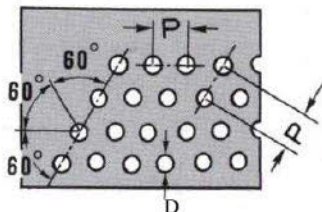

- P: Pitch 0.098 inch (2.5mm)
- D: Diameter 0.059 inch (1.5mm)
- A: Total Screen Area
- O: Open Area %
- S: Total Open area

Dimensions

Mark	Size	1/2"	3/4"	1"	1 1/4"	1 1/2"	2"	2 1/2"	3"
		15mm	20mm	25mm	32mm	40mm	50mm	65mm	80mm
L	in.	3.15	3.94	4.53	5.31	6.30	7.68	8.66	9.45
	mm	80	100	115	135	160	195	220	240
L ₁	in.	2.36	2.87	3.39	3.90	4.41	5.71	7.05	7.72
	mm	60	73	86	99	112	145	179	196
H	in.	2.01	2.44	2.91	3.23	3.70	4.76	5.79	6.50
	mm	51	62	74	82	94	121	147	165
d	in.	0.59	0.79	0.98	1.26	1.57	1.97	2.40	2.99
	mm	15	20	25	32	40	50	61	76
Wt.	lb	0.64	1.04	1.65	2.71	3.79	6.19	9.61	13.69
	kg	0.29	0.47	0.75	1.23	1.72	2.81	4.36	6.21

Data of screen

Mark	Size	1/2"	3/4"	1"	1 1/4"	1 1/2"	2"	2 1/2"	3"
		15mm	20mm	25mm	32mm	40mm	50mm	65mm	80mm
A	cm ²	18.65	31.77	49.17	75.74	110.53	178.04	224.18	296.89
O	%	28.5	28.5	28.5	28.5	28.5	28.5	28.5	28.5
S	cm ²	5.32	9.06	14.01	21.59	31.15	50.74	63.89	84.61

*Design and materials are subject to change without notice.